

# The Physics of Doppler Ultrasound

# 1 The Doppler Principle

The basis of Doppler ultrasonography is the fact that reflected/scattered ultrasonic waves from a moving interface will undergo a frequency shift. In general the magnitude and the direction of this shift will provide information regarding the motion of this interface. To appreciate this very general fact we need to consider the relationship between the frequency,  $f_S$ , of waves produced by a *moving source* and the frequency,  $f_R$ , of the waves received by a *moving receiver*. For simplicity we shall assume that the source and receiver are moving along the same line. The argument that follows will generalise to three dimensions if wave speed is isotropic and the source produces spherical waves.

At  $t = 0$ , let the source,  $S$ , and receiver,  $R$ , be separated by a distance  $d$

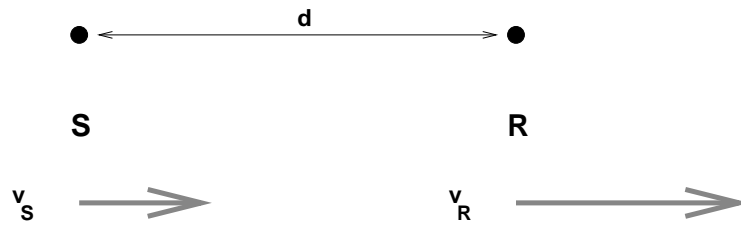

At  $t = 0$  let  $S$  emit a wave that reaches  $R$  at a time  $t$  later

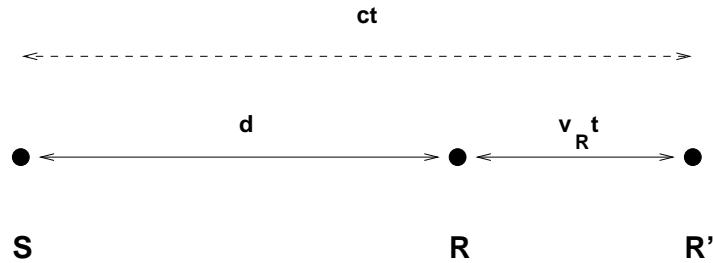

In this time  $t$  the receiver will have moved a distance  $v_R t$  and the wave, propagating with velocity  $c$  will have traveled a distance  $ct$ . Thus

$$ct = d + v_R t \quad \text{or}$$

$$t = \frac{d}{c - v_R}$$

Now at time  $\tau$ , the source will have moved a distance  $\tau v_S$ . Let the wave emitted at that instant be received at time  $t'$  by  $R$ .

In this time  $R$  would have traveled a total distance of  $v_R t'$ , and thus



The last term on the right-hand side can be expanded using the binomial expansion

$$(1 + x)^n = 1 + nx + \frac{n(n-1)}{2!}x^2 + \dots$$

thus for  $x \ll 1$ , higher order terms become unimportant and thus

$$\begin{aligned} f_R &\simeq \left(1 - \frac{v_R}{c}\right) \left(1 + \frac{v_S}{c}\right) \\ &= \left(1 - \frac{v_{RS}}{c}\right) f_S \end{aligned}$$

where  $v_{RS} = v_R - v_S$  is the velocity of the receiver relative to the source. Thus the **Doppler shift** is

$$f_R - f_S = f_D = \frac{-v_{RS}}{c} f_S \quad (2)$$

thus the frequency measured by a receiver moving *away* from a source will be less than the frequency measured at the source, whereas the frequency measured by a receiver moving *towards* a source will be greater than the frequency measured at the source.

## 2 Continuous Wave Doppler Ultrasound

In the field of continuous wave Doppler ultrasound the source and receiver are stationary. In addition the transmitting and receiving transducers may not be in line <sup>2</sup> Let  $\theta_t$  be the angle of the transmitter to the direction of motion and let  $\theta_r$  be the angle of the receiver to the direction of motion. Then the velocity of the scatterer relative to the transmitter will be

$$v \cos(\theta_t)$$

and the velocity of the scatterer relative to the receiver will be

$$v \cos(\theta_r)$$

---

<sup>2</sup>Modern pulsed Doppler however uses the same transducer to transmit and receive.

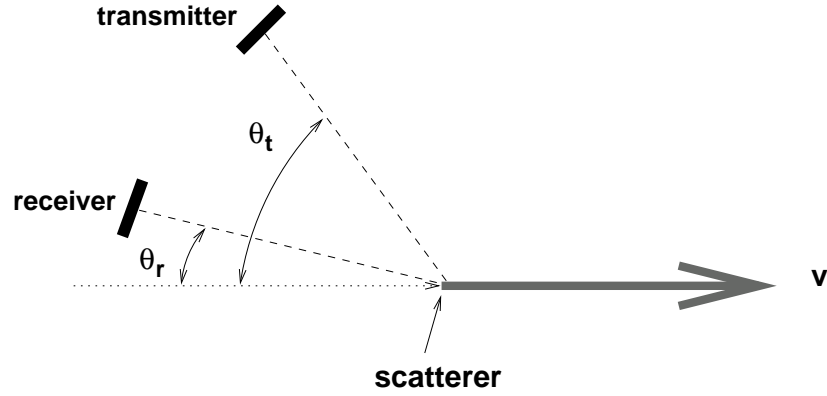

The Doppler shift arising from a moving reflector/scatterer can be calculated by assuming that

- the reflector/scatterer is a receiver moving away from the source with velocity  $v \cos(\theta_t)$ .
- that the receiver is moving away from the reflector/scatterer (source) with velocity  $v \cos(\theta_r)$

This is equivalent to the receiver moving away from the source with velocity  $v \cos(\theta_t) + v \cos(\theta_r)$  even though both the receiver and transducer are stationary. Thus from equation 2 we have

$$\begin{aligned}
 f_D &= -\frac{f_S v}{c} \{ \cos(\theta_t) + \cos(\theta_r) \} \\
 &= -\frac{2f_S v}{c} \cos\left(\frac{\theta_r + \theta_t}{2}\right) \cos\left(\frac{\theta_r - \theta_t}{2}\right)
 \end{aligned}$$

for  $\theta_t \approx \theta_r$  we have

$$f_D = -\frac{2f_S v}{c} \cos(\theta) \tag{3}$$

where  $v \cos(\theta)$  is the velocity of the reflector/scatterer relative to the receiver/transmitter. This equation shows

- $f_D \propto f_S$ . When considerations of
  - increased ultrasound attenuation with frequency

- increased back-scatter signal power with increasing frequency
- desired beam width

are taken into account  $f_S$  is chosen to be  $2 - 20 \text{ MHz}$ .

- $f_D \propto v$ .
- $f_D \propto 1/c$ .
- $f_D$  is dependent on the angles the transmitter and receiver beams make with the velocity vector. In particular if the receiver and transmitter beams are perpendicular to blood flow  $f_D = 0$ .
- if  $v > 0$  then  $f_D < 0$  and if  $v < 0$  then  $f_D > 0$ .

### 3 The Continuous Wave Doppler Instrument

#### 3.1 Basis of operation

This section outlines the basis of the instrumentation required to detect Doppler shifts in received ultrasound. Let the transmitted signal be of the form

$$x_t(t) = \xi_t \cos(\omega_S t)$$

and the corresponding signal received from *one* scatterer be given as

$$x_r(t) = \xi_r \cos([\omega_S + \omega_D]t + \theta_1)$$

where

- $\omega_S = 2\pi f_S$
- $\omega_R = 2\pi f_R$
- $\theta_1$  is a phase term dependent on the distance of the scatterer from the transducer and phase shifts produced within the receiver.

These two signals can be electronically multiplied together to give

$$\begin{aligned}
x_t(t)x_r(t) &= \xi_t\xi_r \cos(\omega_S t) \cos([\omega_S + \omega_D]t + \theta_1) \\
&= \frac{\xi_t\xi_r}{2} \{\cos(\omega_D t + \theta_1) + \cos([2\omega_S + \omega_D]t + \theta_1)\} \quad (4)
\end{aligned}$$

This resulting signal is then **low-pass** filtered to remove the  $2f_S$  source frequency leaving the Doppler signal

$$x_D(t) = \frac{\xi_t\xi_r}{2} \cos(\omega_D t + \theta_1) \quad (5)$$

However further analogue signal processing may be required because the received ultrasound signal also consists of reflected ultrasound of much greater amplitude ( $\geq 40 - 50dB$  than backscattered signal from moving scatterer eg blood). Such reflected ultrasound exhibits a low frequency Doppler shift because of movement of the reflecting tissues eg. pulsating arteries and movement of the probe (if hand-held). For this reason some form of **high-pass** filtering may be required to remove this artefact. Such a procedure will unavoidably lose low frequency Doppler signals from slowly moving blood which may be of clinical significance.

### 3.2 Discrimination of the direction of flow

The Doppler instrument described so far is unable to provide us with any information regarding the direction of motion. In instances where Doppler ultrasound is used to assess blood flow the direction of blood flow may have diagnostic significance. For example, in veins with incompetent valves or A-V malformations/fistulas. The directional information can be preserved in a number of ways

- side-band filtering
- offset carrier demodulation
- in-phase/quadrature demodulation

We will consider each of these techniques in turn. In the descriptions that follow it must be remembered that

- $\omega_D > 0$  implies that velocity vector components along the beam are directed *towards* the probe.
- $\omega_D < 0$  implies that velocity vector components along the beam are directed *away* from the probe.

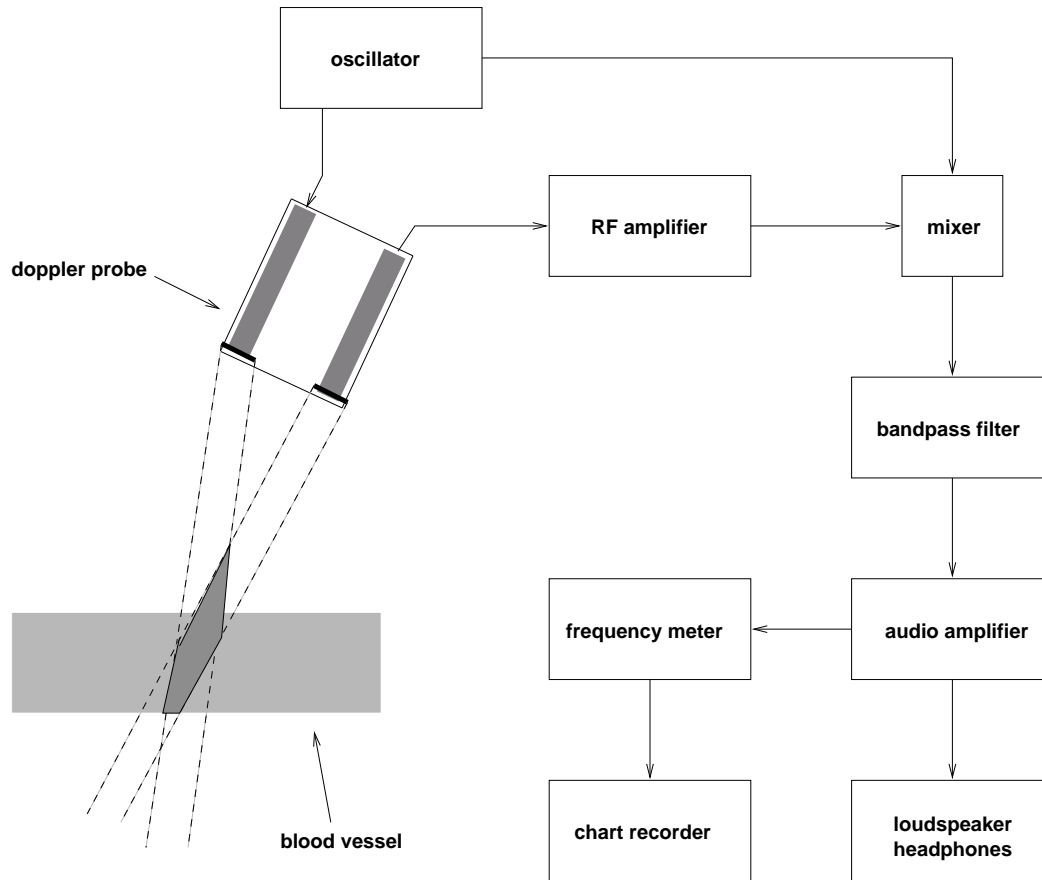

Generic continuous wave Doppler instrumentation

### 3.2.1 Side-band filtering

This method is probably the simplest. The received rf signal is passed to two filters, one passing frequencies over the range  $\omega_S < \omega < \omega_S + \omega_m$  and the other passing frequencies over the range  $\omega_S - \omega_m < \omega < \omega_S$ . The output of each filter passes to a multiplier and bandpass filter as before.

### 3.2.2 Offset carrier demodulation

In this method of determining the direction of flow the received signal is multiplied by a reference signal  $\omega_1 + \omega_S$ . Thus as before the received signal is given by

$$x_r(t) = \xi_r \cos([\omega_S + \omega_D]t + \theta_1)$$

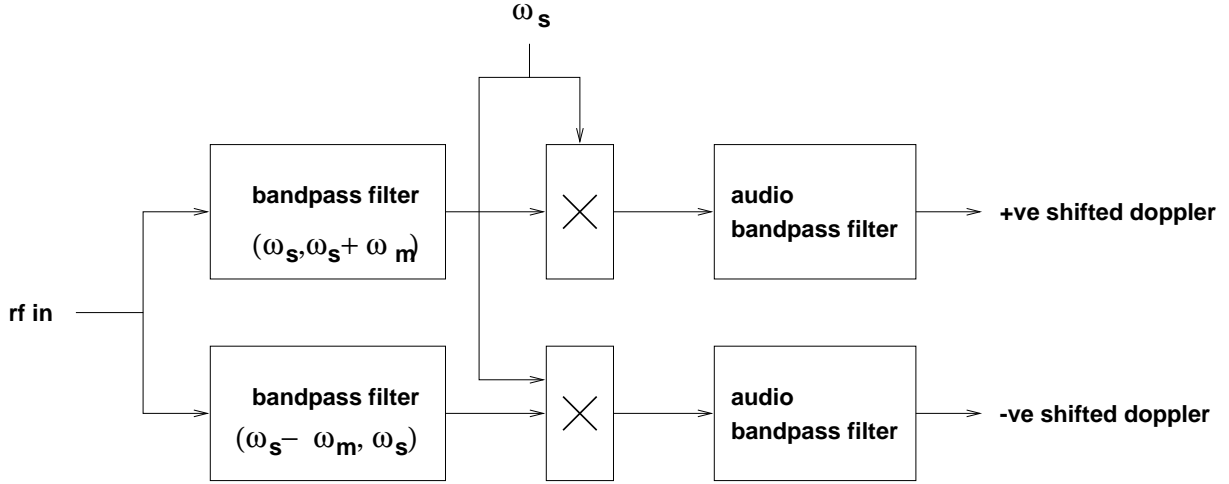

Side-band filtering

the reference signal is given by

$$x_1(t) = \xi_1 \cos([\omega_S + \omega_1]t)$$

Multiplying these two signals together gives

$$x_1(t)x_r(t) = \frac{\xi_1 \xi_r}{2} \{ \cos([\omega_1 + \omega_D]t + \theta_1) + \cos([2\omega_S + \omega_1 + \omega_D]t + \theta_1) \}$$

where  $\omega_1$  is chosen such that  $\omega_1 \geq |\omega_{D,max}|$ . As before this multiplied signal is low pass filtered to remove the  $> 2\omega_S$  component. Thus

$$\begin{aligned} \omega_1 + \omega_D &> \omega_1 \quad \text{+ve shifted doppler} \\ \omega_1 + \omega_D &< \omega_1 \quad \text{-ve shifted doppler} \end{aligned}$$

Note our tissue movement rejection filter is now a **band-stop** filter with a centre frequency of  $\omega_1$ .

### 3.2.3 In-phase/quadrature demodulation

The received signal is passed to two separate multipliers, one, the in phase reference, multiplies the signal by

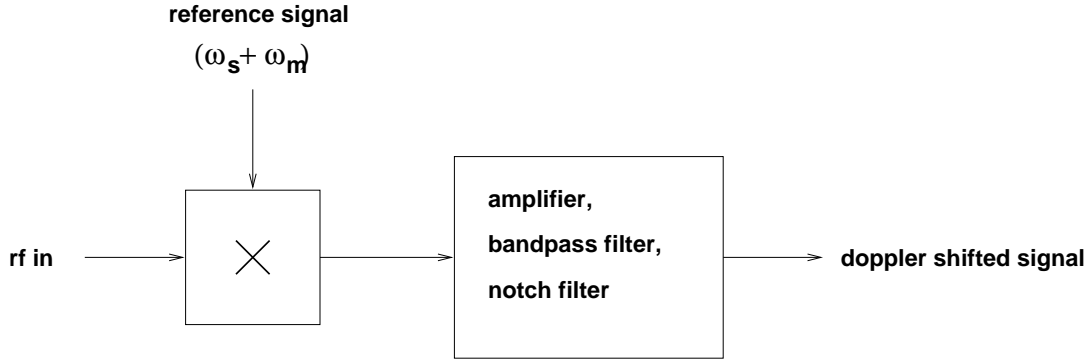

Offset carrier demodulation

$$x_{ip}(t) = \xi_t \cos(\omega_S t)$$

whereas the second, a  $+\pi/2$  phase-shifted reference, multiplies the signal by

$$\begin{aligned} x_{ps}(t) &= \xi_t \cos(\omega_S t + \pi/2) \\ &= -\xi_t \sin(\omega_S t) \end{aligned}$$

The *in-phase signal*,  $i(t)$ , is given as before, as

$$\begin{aligned} i(t) &= x_r(t)x_{ip}(t) \\ &= \frac{\xi_r \xi_t}{2} \{ \cos(\omega_D t + \theta_1) + \cos([2\omega_S + \omega_D]t + \theta_1) \} \end{aligned}$$

and the **quadrature phase signal**,  $q(t)$ , is given by

$$\begin{aligned} q(t) &= x_r(t)x_{ps}(t) \\ &= -\xi_r \xi_t \sin(\omega_S t) \cos([\omega_S + \omega_D]t + \theta_1) \\ &= \frac{\xi_r \xi_t}{2} \{ \sin(\omega_D t + \theta_1) - \sin([2\omega_S + \omega_D]t + \theta_1) \} \end{aligned}$$

Both  $i(t)$  and  $q(t)$  are band-pass filtered and amplified as before to give

$$i_f(t) = \cos(\omega_D t + \theta_1)$$

$$q_f(t) = \sin(\omega_D t + \theta_1)$$

The direction of the Doppler shift, and hence the direction of flow, is determined by noting the phase relationship between  $i_f(t)$  and  $q_f(t)$ , i.e

- $\omega_D > 0$  then  $q_f(t)$  is  $\pi/2$  phase **retarded** with respect to  $i_f(t)$ .
- $\omega_D < 0$  then  $q_f(t)$  is  $\pi/2$  phase **advanced** with respect to  $i_f(t)$ .

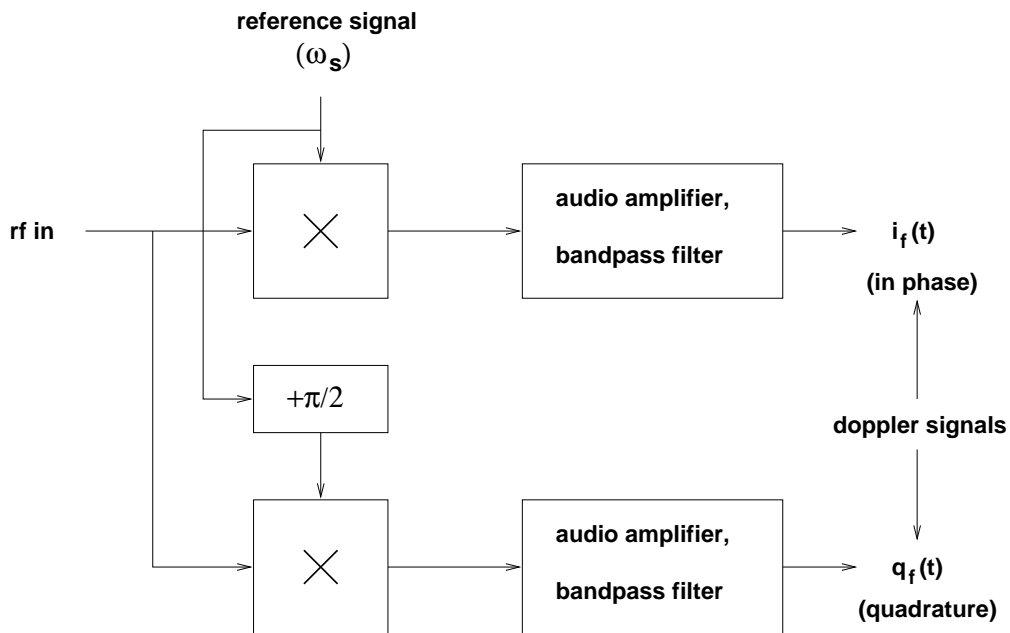

In-phase/quadrature demodulation

## 4 Pulsed Doppler Flow Detectors

There are problems associated with conventional continuous wave (CW) Doppler instrumentation, particularly when used as a flow detector. The most important one being that CW is unable to provide range resolution. In other words CW is not able to separate Doppler signals arising from different points along the transmitted ultrasound beam. Thus if two blood vessels intersect the ultrasonic beam it is not possible to separate velocities at the different points along the beam. The use of **Pulsed Doppler** is able to overcome this problem. The significant differences between CW Doppler and Pulsed Doppler are

- a single transducer is used for transmission and reception as transmission and reception are separated in time.
- pulsed Doppler is often incorporated as an additional signal processing step in conventional pulse echo ultrasound (often known as duplex scanning).
- periodic bursts of ultrasound (e.g a few cycles) are used.
- pulsed Doppler in general is only sensitive to flow within a region termed the **sampling volume**.

Range resolution in pulsed Doppler is achieved by transmitting a short burst of ultrasound. Following the burst the received signal is mixed with a delayed version of the transmitted burst as a reference signal. The transit time of the transmitted pulse to the region of interest and back again is equal to this delay. Thus the *sampling volume* can be moved to different positions along the beam by altering this delay. The implications of this are clear: flow at different depths or at different points within a vessel can be selectively monitored. The width of the *sampling volume* will be proportional to the width of the transmitted ultrasound beam, whereas the length of this sampling volume will be proportional to the duration of the transmitted burst of ultrasound.

## 5 References

Evans D H. *Doppler Ultrasound: Physics, Instrumentation and Clinical Applications*. Wiley, Chichester. 1989.

Hill C R (ed). *Physical Principles of Medical Ultrasonics*. Ellis Horwood, Chichester. 1986.

Webb S (ed). *The Physics of Medical Imaging*. IOP Publishing, Bristol. 1992. pp 319-388.